



# WPLPE

经济型直角行星减速机，适用于承载力很大的工况中  
可进行多面安装，终生润滑，免维护

这款 **WPLPE** 是我们在经济型产品领域的智能型直角式解决方案：节省空间，性能强劲，且价格十分合理。驱动元件可直接安装在输出轴上，在实际应用中获得最佳灵活度。

The economical right angle planetary gearbox for particularly high forces – flexible installation options and lifetime lubrication

The **WPLPE** is the smart right angle solution from our Economy Line: Space-saving, and yet powerful at an attractive price. You install your drive elements directly on the output shaft and extract the maximum flexibility from your application.

额定扭矩  
Nominal output torque **5 - 195 Nm**

径向力  
Radial force **800 - 2500 N**

轴向力  
Axial force **1000 - 4000 N**

回程间隙  
Torsional backlash **11 - 25 arcmin**

防护等级  
Protection class **IP54**

结构尺寸  
Frame sizes

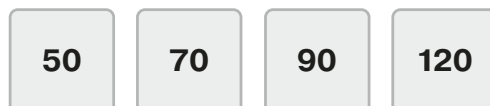

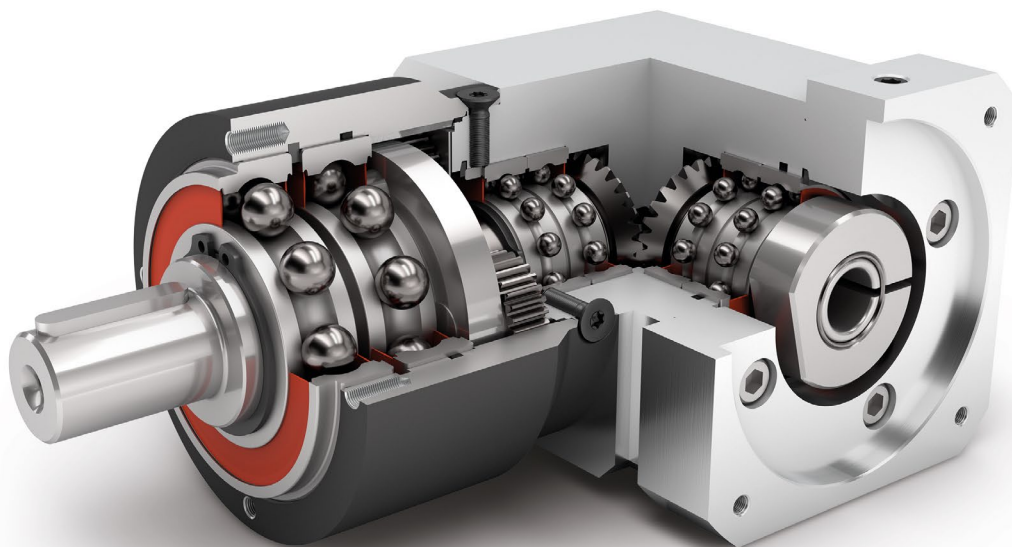

经济型  
Economy Line



直角型减速机  
Right angle gearbox



旋转方向 同方向  
Equidirectional rotation



直齿  
Spur gear



锥齿轮 直角箱  
Bevel gear right angle stage

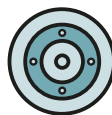

圆形输出法兰  
Round type output flange



增强深沟球轴承  
Reinforced deep groove ball bearings



行星齿轮架  
Planet carrier in disc design

技术特点的详细解释，请从第169页读起。  
Detailed explanations of the technical features starting on page 169.

| Code | 减速机参数                         | Gearbox characteristics  |                  |             | WPLPE050  | WPLPE070  | WPLPE090   | WPLPE120    | p <sup>(1)</sup> |  |
|------|-------------------------------|--|------------------|-------------|-----------|-----------|--|-------------|------------------|--|
|      | 使用寿命 (L <sub>10h</sub> )      | Service life (L <sub>10h</sub> )                                     | t <sub>L</sub>   | h           | 20.000    |           |  |             |                  |  |
|      | T <sub>2N</sub> × 0,88 时的使用寿命 | Service life at T <sub>2N</sub> × 0,88                               |                  |             | 30.000    |           |  |             |                  |  |
|      | 满载时效率 <sup>(2)</sup>          | Efficiency at full load <sup>(2)</sup>                               | η                | %           | 95        |           |  |             | 1                |  |
|      | 最低工作温度                        | Min. operating temperature   | T <sub>min</sub> | °C          | -25       |           |  |             |                  |  |
|      | 最高工作温度                        | Max. operating temperature   | T <sub>max</sub> |             | 90        |           |  |             |                  |  |
|      | 防护等级                          | Protection class   |                  |             |           |           | IP54   |             |                  |  |
| S    | 标准润滑                          | Standard lubrication   |                  |             |           |           | 润滑脂 (终生润滑) / Grease (lifetime lubrication)                                     |             |                  |  |
| F    | 食品级润滑                         | Food grade lubrication   |                  |             |           |           | 润滑脂 (终生润滑) / Grease (lifetime lubrication)                                     |             |                  |  |
| L    | 低温润滑 <sup>(3)</sup>           | Low temperature lubrication <sup>(3)</sup>                           |                  |             |           |           | 润滑脂 (终生润滑) / Grease (lifetime lubrication)                                     |             |                  |  |
|      | 安装位置                          | Installation position  |                  |             |           |           | 任意 / Any   |             |                  |  |
| S    | 标准回程间隙                        | Standard backlash  | j <sub>t</sub>   | arcmin      | < 21      | < 16      | < 13   | < 11        | 1                |  |
|      |                               |  |                  |             | < 25      | < 18      | < 15   | < 13        | 2                |  |
|      | 抗扭刚度 <sup>(2)</sup>           | Torsional stiffness <sup>(2)</sup>                                   | c <sub>G</sub>   | Nm / arcmin | 0,5 - 0,8 | 2,2 - 4,1 | 4,7 - 10,8   | 13,1 - 28,0 | 1                |  |
|      |                               |  |                  |             | 0,7 - 1,0 | 3,3 - 5,3 | 9,0 - 14,1   | 19,5 - 38,5 | 2                |  |
|      | 减速机重量 <sup>(2)</sup>          | Gearbox weight <sup>(2)</sup>  | m <sub>G</sub>   | kg          | 0,8       | 2,1 - 2,2 | 4,8 - 4,9  | 11,5 - 11,6 | 1                |  |
|      |                               |  |                  |             | 1,0 - 1,3 | 2,4 - 2,6 | 5,5 - 5,6  | 13,4 - 13,7 | 2                |  |
| S    | 标准的箱体表面                       | Standard surface   |                  |             |           |           | 箱体: 钢 - 热处理后氧化 (黑色)<br>Housing: Steel - heat-treated and post-oxidized (black) |             |                  |  |
|      | 运行噪音 <sup>(4)</sup>           | Running noise <sup>(4)</sup>   | Q <sub>G</sub>   | dB(A)       | 68        | 70        | 73   | 75          |                  |  |
|      | 基于减速机输入法兰的最大弯矩 <sup>(5)</sup> | Max. bending moment based on the gearbox input flange <sup>(5)</sup> | M <sub>b</sub>   | Nm          | 2         | 5         | 10,5   | 26          |                  |  |

| 输出轴载荷                           | Output shaft loads                            |                       |    | WPLPE050 | WPLPE070 | WPLPE090 | WPLPE120 | p <sup>(1)</sup> |
|---------------------------------|---|-----------------------|----|----------|----------|----------|----------|------------------|
| 20,000 h 的径向力 <sup>(6)(7)</sup> | Radial force for 20,000 h <sup>(6)(7)</sup>   | F <sub>r20.000h</sub> | N  | 800      | 1050     | 1900     | 2500     |                  |
| 20,000 h 的轴向力 <sup>(6)(7)</sup> | Axial force for 20,000 h <sup>(6)(7)</sup>    | F <sub>a20.000h</sub> |    | 1000     | 1350     | 2000     | 4000     |                  |
| 30,000 h 的径向力 <sup>(6)(7)</sup> | Radial force for 30,000 h <sup>(6)(7)</sup>   | F <sub>r30.000h</sub> |    | 700      | 900      | 1700     | 2150     |                  |
| 30,000 h 的轴向力 <sup>(6)(7)</sup> | Axial force for 30,000 h <sup>(6)(7)</sup>    | F <sub>a30.000h</sub> |    | 800      | 1000     | 1500     | 3000     |                  |
| 最大径向力 <sup>(7)(8)</sup>         | Maximum radial force <sup>(7)(8)</sup>        | F <sub>r Stat</sub>   |    | 1300     | 1650     | 3100     | 4000     |                  |
| 最大轴向力 <sup>(7)(8)</sup>         | Maximum axial force <sup>(7)(8)</sup>         | F <sub>a Stat</sub>   |    | 1000     | 2100     | 3800     | 5900     |                  |
| 20,000 h 倾斜力矩 <sup>(6)(8)</sup> | Tilting moment for 20,000 h <sup>(6)(8)</sup> | M <sub>K20.000h</sub> | Nm | 26       | 42       | 99       | 168      |                  |
| 30,000 h 倾斜力矩 <sup>(6)(8)</sup> | Tilting moment for 30,000 h <sup>(6)(8)</sup> | M <sub>K30.000h</sub> |    | 22       | 36       | 89       | 144      |                  |

| 转动惯量                | Moment of inertia                     |   |                   | WPLPE050      | WPLPE070      | WPLPE090      | WPLPE120      | p <sup>(1)</sup> |
|---------------------|---------------------------------------|---|-------------------|---------------|---------------|---------------|---------------|------------------|
| 转动惯量 <sup>(2)</sup> | Mass moment of inertia <sup>(2)</sup> | J | kgcm <sup>2</sup> | 0,032 - 0,052 | 0,218 - 0,329 | 0,925 - 1,408 | 1,861 - 3,248 | 1                |
|                     |                                       |   |                   | 0,031 - 0,049 | 0,218 - 0,326 | 0,907 - 1,245 | 1,818 - 2,818 | 2                |

(1) 减速机级数

(2) 传动比相关的数值可在 Tec Data Finder 中检索 - www.neugart.com

(3) T<sub>min</sub> = -40°C. 理想运行温度最高为 50°C(4) 距离减速机 1 m 时; 在输入转速为 n<sub>1</sub>=3000 min<sup>-1</sup> 且无负荷时测得; i=5(5) 最大电机重量\* (单位: kg) = 0.2 × M<sub>b</sub> / 电机长度 (单位: m)

\* 电机重量对称分布

\* 水平和固定的安装位置

(6) 数据以 n<sub>2</sub>=100 min<sup>-1</sup> 的输出轴转速为准。

(7) 以输出轴中心为准

(8) 更改 T<sub>2N</sub>, F<sub>r</sub>, F<sub>a</sub> 以及周期和轴承使用寿命时, 数值存在偏差 (部分较高)。利用 NCP 针对应用进行专门设计 - www.neugart.com

(1) Number of stages

(2) The ratio-dependent values can be retrieved in Tec Data Finder - www.neugart.com

(3) T<sub>min</sub> = -40°C. Optimal operating temperature max. 50°C(4) Sound pressure level from 1 m, measured on input running at n<sub>1</sub>=3000 rpm no load; i=5(5) Max. motor weight\* in kg = 0.2 × M<sub>b</sub> / motor length in m

\* with symmetrically distributed motor weight

\* with horizontal and stationary mounting

(6) These values are based on an output shaft speed of n<sub>2</sub>=100 rpm

(7) Based on center of output shaft

(8) Other (sometimes higher) values following changes to T<sub>2N</sub>, F<sub>r</sub>, F<sub>a</sub>, cycle, and service life of bearing. Application specific configuration with NCP - www.neugart.com

| 输出扭矩                     | Output torques                          |                   |     | WPLPE050 | WPLPE070 | WPLPE090          | WPLPE120           | i <sup>(1)</sup> | p <sup>(2)</sup> |
|--------------------------|---|-------------------|-----|----------|----------|-------------------|--------------------|------------------|------------------|
| 额定输出扭矩 <sup>(3)(4)</sup> | Nominal output torque <sup>(3)(4)</sup> | T <sub>2N</sub>   | Nm  | 4,5      | 14       | 40 <sup>(5)</sup> | 80 <sup>(5)</sup>  | 3                | 1                |
|                          |   |                   |     | 6        | 19       | 53 <sup>(5)</sup> | 105 <sup>(5)</sup> | 4                |                  |
|                          |   |                   |     | 7,5      | 24       | 67 <sup>(5)</sup> | 130 <sup>(5)</sup> | 5                |                  |
|                          |   |                   |     | 8,5      | 25       | 65                | 135                | 7                |                  |
|                          |   |                   |     | 6        | 18       | 50                | 120                | 8                |                  |
|                          |   |                   |     | 5        | 15       | 38                | 95                 | 10               |                  |
|                          |   |                   |     | 12       | 33       | 97                | 157                | 9                | 2                |
|                          |   |                   |     | 15       | 33       | 90                | 195                | 12               |                  |
|                          |   |                   |     | 13       | 33       | 82                | 172                | 15               |                  |
|                          |   |                   |     | 15       | 33       | 90                | 195                | 16               |                  |
|                          |   |                   |     | 15       | 33       | 90                | 195                | 20               |                  |
|                          |   |                   |     | 13       | 30       | 82                | 172                | 25               |                  |
|                          |   |                   |     | 15       | 33       | 90                | 195                | 32               |                  |
|                          |   |                   |     | 13       | 30       | 82                | 172                | 40               |                  |
| 7,5                      | 18                                      | 50                | 120 | 64       |          |                   |                    |                  |                  |
| 5                        | 15                                      | 38                | 95  | 100      |          |                   |                    |                  |                  |
| 最大输出扭矩 <sup>(4)(6)</sup> | Max. output torque <sup>(4)(6)</sup>    | T <sub>2max</sub> | Nm  | 7        | 22       | 64                | 128                | 3                | 1                |
|                          |   |                   |     | 10       | 30       | 85                | 168                | 4                |                  |
|                          |   |                   |     | 12       | 38       | 107               | 208                | 5                |                  |
|                          |   |                   |     | 13,5     | 40       | 104               | 216                | 7                |                  |
|                          |   |                   |     | 10       | 29       | 80                | 192                | 8                |                  |
|                          |   |                   |     | 8        | 24       | 61                | 152                | 10               |                  |
|                          |   |                   |     | 19       | 53       | 155               | 251                | 9                | 2                |
|                          |   |                   |     | 24       | 53       | 144               | 312                | 12               |                  |
|                          |   |                   |     | 21       | 53       | 131               | 275                | 15               |                  |
|                          |   |                   |     | 24       | 53       | 144               | 312                | 16               |                  |
|                          |   |                   |     | 24       | 53       | 144               | 312                | 20               |                  |
|                          |   |                   |     | 21       | 48       | 131               | 275                | 25               |                  |
|                          |   |                   |     | 24       | 53       | 144               | 312                | 32               |                  |
|                          |   |                   |     | 21       | 48       | 131               | 275                | 40               |                  |
| 12                       | 29                                      | 80                | 192 | 64       |          |                   |                    |                  |                  |
| 8                        | 24                                      | 61                | 152 | 100      |          |                   |                    |                  |                  |

WPLPE

<sup>(1)</sup> 传动比 (i=n<sub>1</sub>/n<sub>2</sub>)  
<sup>(2)</sup> 减速机级数  
<sup>(3)</sup> 利用 NCP 针对应用进行专门设计 – www.neugart.com  
<sup>(4)</sup> 平键 (代码 "A")时的数值; 针对交变载荷  
<sup>(5)</sup> T<sub>2N</sub> 作用时 寿命不是10.000 h  
<sup>(6)</sup> 允许输出轴转动30.000转; 参见第 158 页

<sup>(1)</sup> Ratios (i=n<sub>1</sub>/n<sub>2</sub>)  
<sup>(2)</sup> Number of stages  
<sup>(3)</sup> Application specific configuration with NCP – www.neugart.com  
<sup>(4)</sup> Values for feather key (code "A"): for repeated load  
<sup>(5)</sup> Different service life: 10,000 h at T<sub>2N</sub>  
<sup>(6)</sup> 30,000 rotations of the output shaft permitted; see page 159

| 输出扭矩                | Output torques                       |                    |    | WPLPE050 | WPLPE070 | WPLPE090 | WPLPE120 | i <sup>(1)</sup> | p <sup>(2)</sup> |
|---------------------|--------------------------------------|--------------------|----|----------|----------|----------|----------|------------------|------------------|
| 急停扭矩 <sup>(3)</sup> | Emergency stop torque <sup>(3)</sup> | T <sub>2Stop</sub> | Nm | 22,5     | 66       | 180      | 360      | 3                | 1                |
|                     |                                      |                    |    | 28       | 86       | 240      | 474      | 4                |                  |
|                     |                                      |                    |    | 35       | 80       | 220      | 500      | 5                |                  |
|                     |                                      |                    |    | 26       | 80       | 178      | 340      | 7                |                  |
|                     |                                      |                    |    | 27       | 80       | 190      | 380      | 8                |                  |
|                     |                                      |                    |    | 25       | 70       | 170      | 430      | 10               |                  |
|                     |                                      |                    | 2  | 33       | 88       | 260      | 500      | 9                |                  |
|                     |                                      |                    |    | 40       | 88       | 240      | 520      | 12               |                  |
|                     |                                      |                    |    | 36       | 88       | 220      | 500      | 15               |                  |
|                     |                                      |                    |    | 40       | 88       | 240      | 520      | 16               |                  |
|                     |                                      |                    |    | 40       | 88       | 240      | 520      | 20               |                  |
|                     |                                      |                    |    | 36       | 80       | 220      | 500      | 25               |                  |
|                     |                                      |                    |    | 40       | 88       | 240      | 520      | 32               |                  |
|                     |                                      |                    |    | 36       | 80       | 220      | 500      | 40               |                  |
|                     |                                      |                    |    | 27       | 80       | 190      | 380      | 64               |                  |
|                     |                                      |                    |    | 27       | 80       | 170      | 430      | 100              |                  |

| 输入转速   | Input speeds  |                 |                   | WPLPE050 | WPLPE070                | WPLPE090                                   | WPLPE120            | i <sup>(1)</sup>    | p <sup>(2)</sup> |       |      |      |  |   |
|--|---|-----------------|-------------------|----------|-------------------------|--|---------------------|---------------------|------------------|-------|------|------|--|---|
| T <sub>2N</sub> 和 S1 时的平均热输入转速 <sup>(4)(5)</sup> | Average thermal input speed at T <sub>2N</sub> and S1 <sup>(4)(5)</sup> | n <sub>1N</sub> | min <sup>-1</sup> | 5000     | 4200 <sup>(6)</sup>     | 3000 <sup>(6)</sup>                        | 2350 <sup>(6)</sup> | 3                   | 1                |       |      |      |  |   |
|  |   |                 |                   | 5000     | 4500 <sup>(6)</sup>     | 3150 <sup>(6)</sup>                        | 2450 <sup>(6)</sup> | 4                   |                  |       |      |      |  |   |
|  |   |                 |                   | 5000     | 4500 <sup>(6)</sup>     | 3250 <sup>(6)</sup>                        | 2600 <sup>(6)</sup> | 5                   |                  |       |      |      |  |   |
|  |   |                 |                   | 5000     | 4500 <sup>(6)</sup>     | 3950 <sup>(6)</sup>                        | 3100 <sup>(6)</sup> | 7                   |                  |       |      |      |  |   |
|  |   |                 |                   | 5000     | 4500                    | 4000 <sup>(6)</sup>                        | 3450 <sup>(6)</sup> | 8                   |                  |       |      |      |  |   |
|  |   |                 |                   | 5000     | 4500                    | 4000                                       | 3500 <sup>(6)</sup> | 10                  |                  |       |      |      |  |   |
|  |   |                 |                   | 2        | 5000                    | 4500 <sup>(6)</sup>                        | 3500 <sup>(6)</sup> | 2950 <sup>(6)</sup> | 9                |       |      |      |  |   |
|  |   |                 |                   |          | 5000                    | 4500                                       | 4000 <sup>(6)</sup> | 3050 <sup>(6)</sup> | 12               |       |      |      |  |   |
|  |   |                 |                   |          | 5000                    | 4500                                       | 4000 <sup>(6)</sup> | 3450 <sup>(6)</sup> | 15               |       |      |      |  |   |
|  |   |                 |                   |          | 5000                    | 4500                                       | 4000 <sup>(6)</sup> | 3450 <sup>(6)</sup> | 16               |       |      |      |  |   |
|  |   |                 |                   |          | 5000                    | 4500                                       | 4000 <sup>(6)</sup> | 3500 <sup>(6)</sup> | 20               |       |      |      |  |   |
|  |   |                 |                   |          | 5000                    | 4500                                       | 4000                | 3500 <sup>(6)</sup> | 25               |       |      |      |  |   |
|  |   |                 |                   |          | 5000                    | 4500                                       | 4000                | 3500                | 32               |       |      |      |  |   |
|  |   |                 |                   |          | 5000                    | 4500                                       | 4000                | 3500                | 40               |       |      |      |  |   |
|  |   |                 |                   |          | 5000                    | 4500                                       | 4000                | 3500                | 64               |       |      |      |  |   |
|  |   |                 |                   |          | 5000                    | 4500                                       | 4000                | 3500                | 100              |       |      |      |  |   |
|  |   |                 |                   |          | 最高机械输入转速 <sup>(4)</sup> | Max. mechanical input speed <sup>(4)</sup> | n <sub>1Limit</sub> | min <sup>-1</sup>   | 18000            | 13000 | 7000 | 6500 |  | 1 |
|  |   |                 |                   |          |                         |  |                     |                     | 18000            | 13000 | 7000 | 6500 |  | 2 |

<sup>(1)</sup> 传动比 (i=n<sub>1</sub>/n<sub>2</sub>)

<sup>(2)</sup> 减速机级数

<sup>(3)</sup> 允许 1000 次

<sup>(4)</sup> 利用 NCP 针对应用设计转速 – www.neugart.com

<sup>(5)</sup> 定义请参见第 158 页

<sup>(6)</sup> 在 50% T<sub>2N</sub> 输出和 S1 模式下 的平均热传动转速

<sup>(1)</sup> Ratios (i=n<sub>1</sub>/n<sub>2</sub>)

<sup>(2)</sup> Number of stages

<sup>(3)</sup> Permitted 1000 times

<sup>(4)</sup> Application-specific speed configurations with NCP – www.neugart.com

<sup>(5)</sup> See page 159 for the definition

<sup>(6)</sup> Average thermal input speed at 50% T<sub>2N</sub> and S1

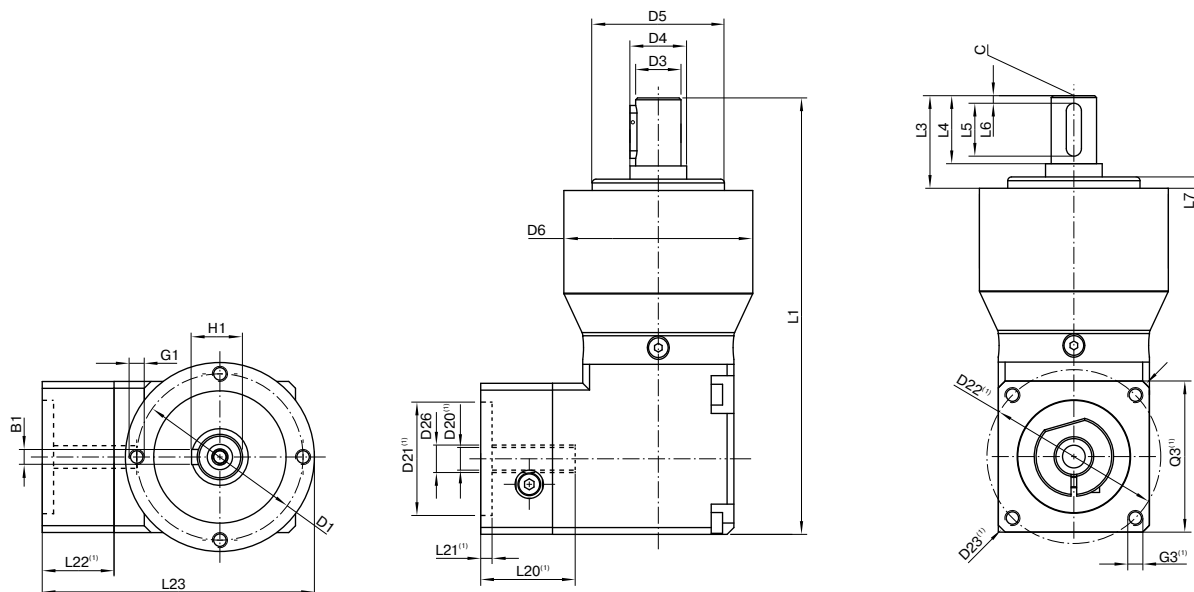

图示为带平键的 WPLPE090 / 1 级 / 附带平键的输出轴 / 19 mm 锁紧系统 / 适配电机法兰 - 2 件式 - 正方形通用法兰 / B5 电机法兰类型  
 Drawing corresponds to a WPLPE090 / 1-stage / output shaft with feather key / 19 mm clamping system / motor adaptation - 2-part - square universal flange / B5 flange type motor

<sup>(1)</sup> 具体尺寸视电机/减速机法兰而定。可以在 [www.neugart.com](http://www.neugart.com) 下 Tec Data Finder。中针对每个电机适配电机特有的输入法兰几何尺寸。  
<sup>(1)</sup> The dimensions vary with the motor/gearbox flange. The input flange dimensions can be retrieved for each specific motor in Tec Data Finder at [www.neugart.com](http://www.neugart.com)

| 几何尺寸 <sup>(2)</sup>   | Geometry <sup>(2)</sup>                         |     |    | WPLPE050   | WPLPE070 | WPLPE090 | WPLPE120  | p <sup>(3)</sup> | Code |
|-----------------------|---|-----|----|--|----------|----------|-----------|------------------|------|
| 输出端安装孔节圆直径            | Pitch circle diameter output                    | D1  |    | 44   | 62       | 80       | 108       |                  |      |
| 输出轴直径                 | Shaft diameter output                           | D3  | k7 | 12   | 16       | 22       | 32        |                  |      |
| 输出轴轴肩直径               | Shaft collar output                             | D4  |    | 15   | 30       | 35       | 50        |                  |      |
| 输出端定位凸台直径             | Centering diameter output                       | D5  | h7 | 35   | 52       | 68       | 90        |                  |      |
| 箱体直径                  | Housing diameter                                | D6  |    | 50   | 70       | 90       | 120       |                  |      |
| 安装螺纹 x 深度             | Mounting thread x depth                         | G1  | 4x | M4x8   | M5x8     | M6x9     | M8x20     |                  |      |
| 总长                    | Total length                                    | L1  |    | 115,5  | 152,5    | 197,5    | 265       | 1                |      |
|                       |   |     |    | 128  | 165,5    | 215,5    | 292,5     | 2                |      |
| 输出轴轴长                 | Shaft length output                             | L3  |    | 24,5   | 36       | 46       | 68        |                  |      |
| 输出端定位凸台深度             | Centering depth output                          | L7  |    | 3  | 3        | 4        | 5         |                  |      |
| 最小总高度                 | Min. overall height                             | L23 |    | 67   | 90,5     | 114,5    | 148       |                  |      |
| 电机轴直径j6/k6            | Motor shaft diameter j6/k6                      | D20 |    | 更多信息见第 155/156 页<br>More information on page 155/156 |          |          |           |                  |      |
| 输入端锁紧系统直径             | Clamping system diameter input                  | D26 |    | 更多信息见第 155/156 页<br>More information on page 155/156 |          |          |           |                  |      |
| 带平键的输出轴 (DIN 6885-1)  | Output shaft with feather key (DIN 6885-1)      |     |    | A 4x4x14   | A 5x5x25 | A 6x6x32 | A 10x8x50 |                  | A    |
| 平键宽度 (DIN 6885-1)     | Feather key width (DIN 6885-1)                  | B1  |    | 4  | 5        | 6        | 10        |                  |      |
| 含平键在内的轴高 (DIN 6885-1) | Shaft height including feather key (DIN 6885-1) | H1  |    | 13,5   | 18       | 24,5     | 35        |                  |      |
| 到轴肩的距离                | Shaft length from shoulder                      | L4  |    | 18   | 28       | 36       | 58        |                  |      |
| 平键长度                  | Feather key length                              | L5  |    | 14   | 25       | 32       | 50        |                  |      |
| 到轴端的距离                | Distance from shaft end                         | L6  |    | 2  | 2        | 2        | 4         |                  |      |
| 中心孔 (DIN 332, DR 形)   | Center hole (DIN 332, type DR)                  | C   |    | M4x10  | M5x12,5  | M8x19    | M12x28    |                  |      |
| 光滑输出轴                 | Smooth output shaft                             |     |    |  |          |          |           |                  | B    |
| 到轴肩的距离                | Shaft length from shoulder                      | L4  |    | 18   | 28       | 36       | 58        |                  |      |

<sup>(2)</sup> 所有的尺寸单位为mm  
<sup>(3)</sup> 减速机级数

<sup>(2)</sup> Dimensions in mm  
<sup>(3)</sup> Number of stages