

# PSBN

高性能精密减速机  
配有高精度斜齿  
驱动运行时安静无噪音

PSBN 是高精度行星减速机和高效轴承科技的完美结合。专为需要在保证高转速的同时达到最优性能的应用情况而设计。借助高精度的斜齿，其运行十分稳定，且比一般的减速机都要安静。

The high-performance precision planetary gearbox with helical gearing for a particularly quiet drive

Our PSBN is the ideal combination of precision planetary gearbox and efficient bearing technology. It has been developed specifically for delivering the maximum performance at high speeds. Its helical teeth provide homogeneous synchronism and quiet running noise.

额定扭矩 Nominal output torque	<b>28 - 470 Nm</b>
径向力 Radial force	<b>1000 - 5800 N</b>
轴向力 Axial force	<b>1500 - 9400 N</b>
回程间隙 Torsional backlash	<b>1 - 5 arcmin</b>
防护等级 Protection class	<b>IP65</b>

结构尺寸  
Frame sizes

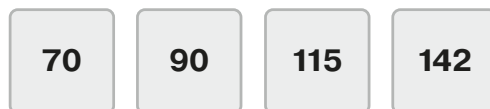

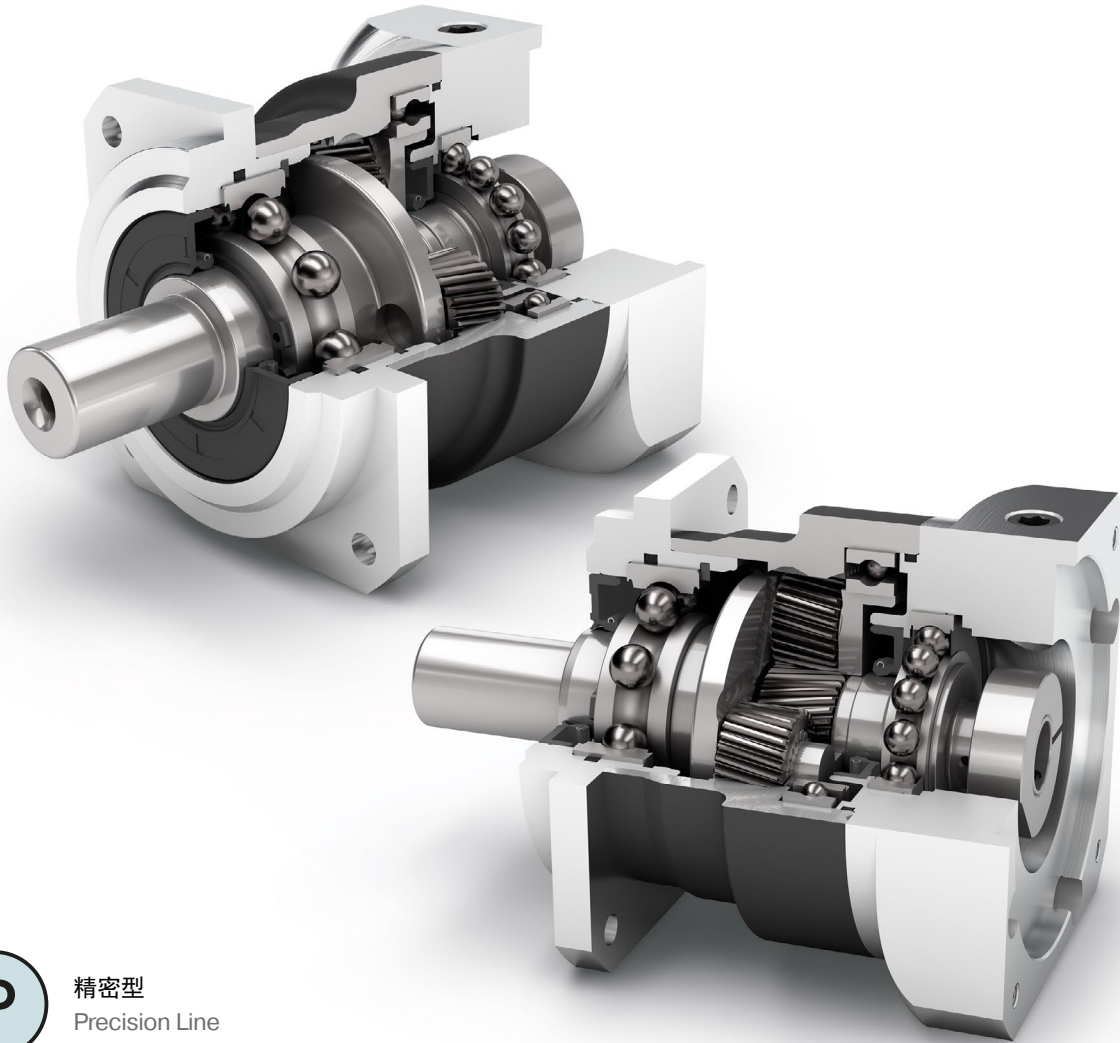

精密型  
Precision Line



同轴减速机  
Coaxial gearbox



斜齿  
Helical gear



低摩擦深沟球轴承  
Low-friction deep groove ball bearings



行星齿轮架（笼状结构）  
Planet carrier in cage design



旋转方向 同方向  
Equidirectional rotation



正方形输出法兰  
Square type output flange



径向轴密封  
Rotary shaft seal



可选：降低回程间隙  
Option: Reduced backlash

技术特点的详细解释，请从第169页读起。  
Detailed explanations of the technical features starting on page 169.

Code	减速机参数	Gearbox characteristics			PSBN070	PSBN090	PSBN115	PSBN142	p <sup>(1)</sup>	
	使用寿命 (L <sub>10h</sub> )	Service life (L <sub>10h</sub> )	t <sub>L</sub>	h	20.000					
	T <sub>2N</sub> × 0,88 时的使用寿命	Service life at T <sub>2N</sub> × 0,88			30.000					
	满载时效率 <sup>(2)</sup>	Efficiency at full load <sup>(2)</sup>	η	%	98				1	
	最低工作温度	Min. operating temperature	T <sub>min</sub>	°C	-25					
	最高工作温度	Max. operating temperature	T <sub>max</sub>		90					
	防护等级	Protection class					IP65			
S	标准润滑	Standard lubrication					润滑油 (终生润滑) / Oil (lifetime lubrication)			
F	食品级润滑	Food grade lubrication					润滑油 (终生润滑) / Oil (lifetime lubrication)			
L	低温润滑 <sup>(3)</sup>	Low temperature lubrication <sup>(3)</sup>					润滑油 (终生润滑) / Oil (lifetime lubrication)			
	安装位置	Installation position					任意 / Any			
S	标准回程间隙	Standard backlash	j <sub>t</sub>	arcmin	< 3				1	
R	降低回程间隙	Reduced backlash			< 5				2	
	抗扭刚度 <sup>(2)</sup>	Torsional stiffness <sup>(2)</sup>	c <sub>g</sub>	Nm / arcmin	4,1 - 5,4	9,3 - 12,8	22,5 - 32,5	59,5 - 76,0	1	
	减速机重量 <sup>(2)</sup>	Gearbox weight <sup>(2)</sup>			m <sub>G</sub>	kg	4,1 - 5,7	10,2 - 13,4	25,5 - 35,0	57,5 - 71,0
					1,4 - 1,5	2,8 - 2,9	5,4 - 5,8	13,4 - 13,7	1	
					2,1	3,4 - 3,5	6,7 - 6,9	15,4 - 15,8	2	
S	标准的箱体表面	Standard surface					箱体: 钢 - 热处理后氧化 (黑色) Housing: Steel - heat-treated and post-oxidized (black)			
	运行噪音 <sup>(4)</sup>	Running noise <sup>(4)</sup>	Q <sub>g</sub>	dB(A)	57	58	63	66		
	基于减速机输入法兰的最大弯矩 <sup>(5)</sup>	Max. bending moment based on the gearbox input flange <sup>(5)</sup>	M <sub>b</sub>	Nm	18	38	80	180	1	
					18	18	38	80	80	2

输出轴载荷	Output shaft loads				PSBN070	PSBN090	PSBN115	PSBN142	p <sup>(1)</sup>
20,000 h 的径向力 <sup>(6)(7)</sup>	Radial force for 20,000 h <sup>(6)(7)</sup>	F <sub>r20.000h</sub>	N		1000	1900	2300	4200 - 5800	
20,000 h 的轴向力 <sup>(6)(7)</sup>	Axial force for 20,000 h <sup>(6)(7)</sup>	F <sub>a20.000h</sub>			1500	3000	4400	9400	
30,000 h 的径向力 <sup>(6)(7)</sup>	Radial force for 30,000 h <sup>(6)(7)</sup>	F <sub>r30.000h</sub>			850	1700	2000	3700 - 5100	
30,000 h 的轴向力 <sup>(6)(7)</sup>	Axial force for 30,000 h <sup>(6)(7)</sup>	F <sub>a30.000h</sub>			1300	2500	3700	7700	
最大径向力 <sup>(7)(8)</sup>	Maximum radial force <sup>(7)(8)</sup>	F <sub>r Stat</sub>			1600	3100	4500	9500	
最大轴向力 <sup>(7)(8)</sup>	Maximum axial force <sup>(7)(8)</sup>	F <sub>a Stat</sub>			1500	2800	4500	9600	
20,000 h 倾斜力矩 <sup>(6)(8)</sup>	Tilting moment for 20,000 h <sup>(6)(8)</sup>	M <sub>K20.000h</sub>	Nm		68	154	226	565 - 794	
30,000 h 倾斜力矩 <sup>(6)(8)</sup>	Tilting moment for 30,000 h <sup>(6)(8)</sup>	M <sub>K30.000h</sub>			58	138	197	495 - 697	

转动惯量	Moment of inertia				PSBN070	PSBN090	PSBN115	PSBN142	p <sup>(1)</sup>
转动惯量 <sup>(2)</sup>	Mass moment of inertia <sup>(2)</sup>	J	kgcm <sup>2</sup>		0,127 - 0,260	0,327 - 0,785	0,874 - 2,650	6,539 - 14,440	1
					0,123 - 0,175	0,124 - 0,200	0,321 - 0,600	0,841 - 2,003	2

(1) 减速机级数  
 (2) 传动比相关的数值可在 Tec Data Finder 中检索 - www.neugart.com  
 (3) T<sub>min</sub> = -40°C. 理想运行温度最高为 50°C  
 (4) 距离减速机 1 m 时; 在输入转速为 n<sub>1</sub>=3000 min<sup>-1</sup> 且无负荷时测得; i=5  
 (5) 最大电机重量\* (单位: kg) = 0.2 × M<sub>b</sub> / 电机长度 (单位: m)  
 \* 电机重量对称分布  
 \* 水平和固定的安装位置  
 (6) 数据以 n<sub>2</sub>=100 min<sup>-1</sup> 的输出轴转速为准。  
 (7) 以输出轴中心为准  
 (8) 更改 T<sub>2N</sub>, F<sub>r</sub>, F<sub>a</sub> 以及周期和轴承使用寿命时; 数值存在偏差 (部分较高)。  
 利用 NCP 针对应用进行专门设计 - www.neugart.com

(1) Number of stages  
 (2) The ratio-dependent values can be retrieved in Tec Data Finder - www.neugart.com  
 (3) T<sub>min</sub> = -40°C. Optimal operating temperature max. 50°C  
 (4) Sound pressure level from 1 m, measured on input running at n<sub>1</sub>=3000 rpm no load; i=5  
 (5) Max. motor weight\* in kg = 0.2 × M<sub>b</sub> / motor length in m  
 \* with symmetrically distributed motor weight  
 \* with horizontal and stationary mounting  
 (6) These values are based on an output shaft speed of n<sub>2</sub>=100 rpm  
 (7) Based on center of output shaft  
 (8) Other (sometimes higher) values following changes to T<sub>2N</sub>, F<sub>r</sub>, F<sub>a</sub>, cycle, and service life of bearing. Application specific configuration with NCP - www.neugart.com

输出扭矩	Output torques			PSBN070	PSBN090	PSBN115	PSBN142	i <sup>(1)</sup>	p <sup>(2)</sup>	
额定输出扭矩 <sup>(3)(4)</sup>	Nominal output torque <sup>(3)(4)</sup>	T <sub>2N</sub>	Nm	29	54	135	380	3	1	
				39	80	180	470	4		
				40	80	175	405	5		
				37	78	175	355	7		
				39	75	155	350	8		
				28	59	140	305	10		
				29	54	135	380	12		
				29	54	135	380	15		
		39	80	180	450	16	2			
		39	80	180	450	20				
		40	80	175	405	25				
		40	80	175	405	35				
		39	80	180	470	40				
		40	80	175	405	50				
		37	78	175	355	70				
		28	59	140	305	100				
最大输出扭矩 <sup>(4)(5)</sup>	Max. output torque <sup>(4)(5)</sup>	T <sub>2max</sub>	Nm	46	86	216	608	3	1	
				62	128	288	752	4		
				64	128	280	648	5		
				59	125	280	568	7		
				62	120	248	560	8		
				45	94	224	488	10		
				46	86	216	608	12		2
				46	86	216	608	15		
		62	128	288	720	16				
		62	128	288	720	20				
		64	128	280	648	25				
		64	128	280	648	35				
		62	128	288	752	40				
		64	128	280	648	50				
		59	125	280	568	70	100			
		45	94	224	488	100				

<sup>(1)</sup> 传动比 (i=n<sub>1</sub>/n<sub>2</sub>)

<sup>(2)</sup> 减速机级数

<sup>(3)</sup> 利用 NCP 针对应用进行专门设计 – www.neugart.com

<sup>(4)</sup> 平键 (代码 "A")时的数值: 针对交变载荷

<sup>(5)</sup> 允许输出轴转动30.000转: 参见第 158 页

<sup>(1)</sup> Ratios (i=n<sub>1</sub>/n<sub>2</sub>)

<sup>(2)</sup> Number of stages

<sup>(3)</sup> Application specific configuration with NCP – www.neugart.com

<sup>(4)</sup> Values for feather key (code "A"): for repeated load

<sup>(5)</sup> 30,000 rotations of the output shaft permitted; see page 159

输出扭矩	Output torques			PSBN070	PSBN090	PSBN115	PSBN142	i <sup>(1)</sup>	p <sup>(2)</sup>
急停扭矩 <sup>(3)</sup>	Emergency stop torque <sup>(3)</sup>	T <sub>2Stop</sub>	Nm	90	210	490	1250	3	1
				120	280	650	1650	4	
				130	280	650	1650	5	
				80	175	340	1300	7	
				90	200	380	1100	8	
				90	200	480	600	10	
				135	220	500	1250	12	2
				135	220	500	1250	15	
				150	300	650	1650	16	
				150	300	650	1650	20	
				150	300	650	1650	25	
				150	300	650	1650	35	
				150	300	650	1650	40	
				150	300	650	1650	50	
				80	175	340	1300	70	
				80	200	480	600	100	

输入转速	Input speeds			PSBN070	PSBN090	PSBN115	PSBN142	i <sup>(1)</sup>	p <sup>(2)</sup>
T <sub>2N</sub> 和 S1 时的平均热输入转速 <sup>(4)(5)</sup>	Average thermal input speed at T <sub>2N</sub> and S1 <sup>(4)(5)</sup>	n <sub>1N</sub>	min <sup>-1</sup>	3800 <sup>(6)</sup>	3400 <sup>(6)</sup>	2900 <sup>(6)</sup>	1600 <sup>(6)</sup>	3	1
				4400 <sup>(6)</sup>	3700 <sup>(6)</sup>	3000 <sup>(6)</sup>	1950 <sup>(6)</sup>	4	
				4600 <sup>(6)</sup>	3900 <sup>(6)</sup>	3500 <sup>(6)</sup>	2350 <sup>(6)</sup>	5	
				5000	4500	4000 <sup>(6)</sup>	3150 <sup>(6)</sup>	7	
				5000	4500	4000	3450 <sup>(6)</sup>	8	
				5000	4500	4000	3500	10	
				5000	5000	4500	3150 <sup>(6)</sup>	12	2
				5000	5000	4500	3950 <sup>(6)</sup>	15	
				5000	5000	4500	3400 <sup>(6)</sup>	16	
				5000	5000	4500	4000 <sup>(6)</sup>	20	
				5000	5000	4500	4000	25	
				5000	5000	4500	4000	35	
				5000	5000	4500	4000	40	
				5000	5000	4500	4000	50	
				5000	5000	4500	4000	70	
				5000	5000	4500	4000	100	
最高机械输入转速 <sup>(4)</sup>	Max. mechanical input speed <sup>(4)</sup>	n <sub>1Limit</sub>	min <sup>-1</sup>	14000	10000	8500	6500		1
				14000	14000	10000	8500		2

<sup>(1)</sup> 传动比 (i=n<sub>1</sub>/n<sub>2</sub>)

<sup>(2)</sup> 减速级数

<sup>(3)</sup> 允许 1000 次

<sup>(4)</sup> 利用 NCP 针对应用设计转速 – www.neugart.com

<sup>(5)</sup> 定义请参见第 158 页

<sup>(6)</sup> 在 50% T<sub>2N</sub> 输出和 S1 模式下的平均热传动转速

<sup>(1)</sup> Ratios (i=n<sub>1</sub>/n<sub>2</sub>)

<sup>(2)</sup> Number of stages

<sup>(3)</sup> Permitted 1000 times

<sup>(4)</sup> Application-specific speed configurations with NCP – www.neugart.com

<sup>(5)</sup> See page 159 for the definition

<sup>(6)</sup> Average thermal input speed at 50% T<sub>2N</sub> and S1

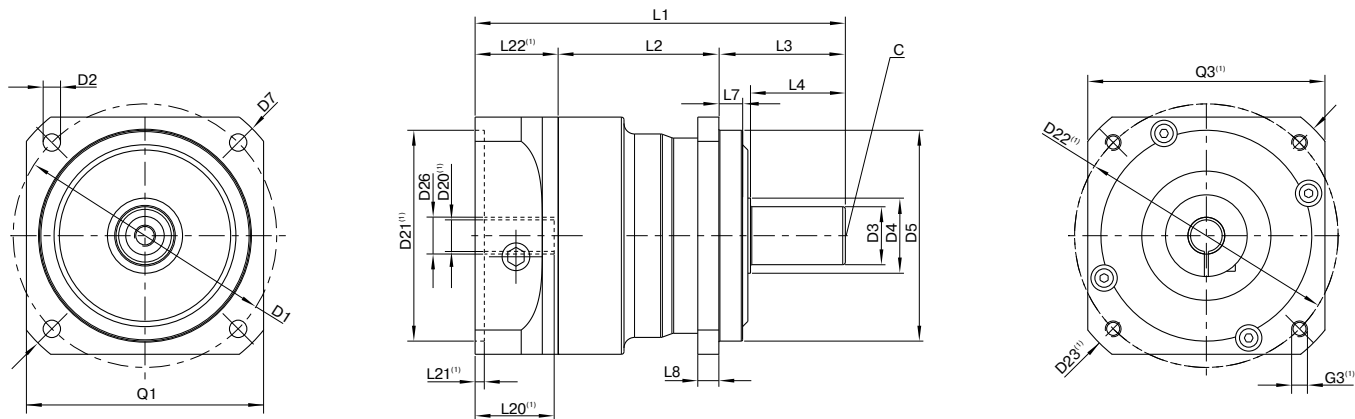

图示为带平键的 PSBN090 / 1 级 / 光滑输出轴 / 14 mm 锁紧系统 / 适配电机法兰 – 2 件式 – 圆形通用法兰 / B5 电机法兰类型  
 Drawing corresponds to a PSBN090 / 1-stage / smooth output shaft / 14 mm clamping system / motor adaptation – 2-part – round universal flange / B5 flange type motor

<sup>(1)</sup> 具体尺寸视电机/减速机法兰而定。可以在 [www.neugart.com](http://www.neugart.com) 下 Tec Data Finder。中针对每个电机适配电机特有的输入法兰几何尺寸。  
<sup>(1)</sup> The dimensions vary with the motor/gearbox flange. The input flange dimensions can be retrieved for each specific motor in Tec Data Finder at [www.neugart.com](http://www.neugart.com)

几何尺寸 <sup>(2)</sup>	Geometry <sup>(2)</sup>			PSBN070	PSBN090	PSBN115	PSBN142	p <sup>(2)</sup>	Code
输出端安装孔节圆直径	Pitch circle diameter output	D1		70	100	130	165		
输出端安装孔直径	Mounting bore output	D2	4x	5,5	6,6	9,0	11,0		
输出轴直径	Shaft diameter output	D3	j6	16	22	32	40		
输出轴轴肩直径	Shaft collar output	D4		23,5	28,5	38,5	48,5		
输出端定位凸台直径	Centering diameter output	D5	g6	50	80	110	130		
输出法兰对角线尺寸	Diagonal dimension output	D7		80	115	148	185		
输出端法兰外方	Flange cross section output	Q1	■	60	90	115	140		
最小总长	Min. total length	L1		116,5	140,5	182,5	247,5	1	
				145	162,5	204,5	278,5	2	
箱体长度	Housing length	L2		54	61	74	100,5	1	
				82,5	89	107,5	138,5	2	
输出轴轴长	Shaft length output	L3		37	48	65	97		
输出端定位凸台深度	Centering depth output	L7		6	9	4	12		
输出端法兰厚度	Flange thickness output	L8		6	8	10	12		
中心孔 (DIN 332, DR 形)	Center hole (DIN 332, type DR)	C		M5x12,5	M8x19	M12x28	M16x36		
电机轴直径j6/k6	Motor shaft diameter j6/k6	D20		更多信息见第 155/156 页 More information on page 155/156					
输入端锁紧系统直径	Clamping system diameter input	D26		更多信息见第 155/156 页 More information on page 155/156					
带平键的输出轴 (DIN 6885-1)	Output shaft with feather key (DIN 6885-1)			A 5x5x25	A 6x6x28	A 10x8x50	A 12x8x65		
平键宽度 (DIN 6885-1)	Feather key width (DIN 6885-1)	B1		5	6	10	12		A
含平键在内的轴高 (DIN 6885-1)	Shaft height including feather key (DIN 6885-1)	H1		18	24,5	35	43		
到轴肩的距离	Shaft length from shoulder	L4		28	36	58	82		
平键长度	Feather key length	L5		25	28	50	65		
到轴端的距离	Distance from shaft end	L6		2	4	4	8		
光滑输出轴	Smooth output shaft								
到轴肩的距离	Shaft length from shoulder	L4		28	36	58	82		B

<sup>(2)</sup> 所有的尺寸单位为mm  
<sup>(3)</sup> 减速机级数

<sup>(2)</sup> Dimensions in mm  
<sup>(3)</sup> Number of stages