

# Miniature Bending Beam Tension and Compression Load Cell

## MODEL 8510

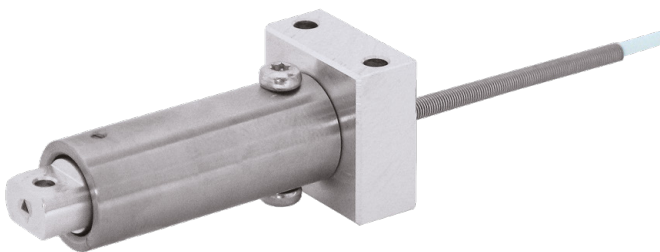

### Highlights

- Measuring ranges from 0 ... 1 N up to 0 ... 20 N, 0 ... 0.224 lbs up to 0 ... 4.4 lbs
- Compact size
- Mechanical bidirectional overload protection
- Easy installation
- Special design upon request

### Options

- Non-linearity 0.075 % F.S.
- Standardized nominal sensitivity
- burster TEDS

### Applications

- Check of switches and buttons (limit-, micro- and toggle-switches)
- Contact coupling and contact decoupling forces
- Recording of frictional forces and spring characteristics
- Research and Development

### Product description

The sensor element consists of a double bending beam with applied strain gages.

Changes in the ohmic resistance of the strain gage fullbridge caused by applied forces are converted into electrical voltages. The precise value (characteristic value) of the output voltage, resulting from the application of a rated force to the sensor, is specified in the accompanying calibration protocol.

The sensor has to be mounted by two screws on the cable side. The opposite side is meant to receive applied forces (loads).

Once the rated stress or strain is exceeded by 20 %, further deflection of the bending beam is prevented by an integrated, mechanical stop. This protects the sensor element against permanent deformation.



Measurement direction



Overload protection

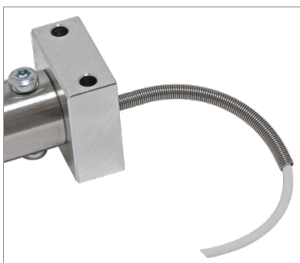

Sensor attachment  
Bending protection

## Technical Data

8510	-	5001	5002	5005	5010	5020
Measuring range calibrated in N from 0 ...		±1 N	±2 N	±5 N	±10 N	±20 N
		±0.224 lbs	±0.449 lbs	±1.124 lbs	±2.248 lbs	±4.496 lbs
<b>Accuracy</b>						
Relative non-linearity*		≤ ±0.2 % F.S.				
Characteristic curve deviation*		≤ ±0.2 % F.S.				
Relative hysteresis		≤ 0.1 % F.S.				
Temperature effect on zero output		0.03 % F.S./K				
Temperature effect on nominal sensitivity		0.03 % F.S./K				
<b>Electrical values</b>						
Sensitivity nominal		1.0 mV/V				
Measurement direction		Tension and compression direction. Load calibration in compression direction (clearly marked by an arrow on the sensor). The full-scale output is likely to be different when used in the tension direction. Positive signal in compression direction.				
Standardization**		option 1.0 mV/V (±0,25 %)				
Bridge resistance		350 Ω nominal (deviations are possible)				
Excitation		max. 3 V DC	max. 5 V DC			
Insulation resistance		> 30 MΩ at 45 V				
<b>Environmental conditions</b>						
Nominal temperature range		+15 °C ... +70 °C				
Operating temperature range		-20 °C ... +80 °C				
<b>Mechanical values</b>						
Deflection full scale		0.15 mm (nominal)				
Maximum operating force***		mechanical stop at approx. 120 % of full scale				
Overload protection		up to 5 N	up to 10 N	up to 15 N	up to 20 N	up to 40 N
Dynamic performance***		recommended: 50 %				
Protection class (EN 60529)		IP20				
<b>Installation</b>						
Intended mounting screws		M3				
Tightening torque mounting screws	[N*m]	0.9 N*m (for steel) / 0.7 N*m (for aluminum)				
Mounting screws		resistance 8.8				
Installation instructions		Two clearance holes designed to accommodate M3 screws are provided for mounting the sensor. On the opposite on the lying side there is a hole for attaching a suitable receptacle for force application. (e.g. a load button or touch finger). For high quality force measurements, lateral forces and moments are avoided.				
<b>Other</b>						
Material		high-strength aluminium, high-grade steel shell				
Natural frequency	[Hz]	100	150	250	300	500
Mass	[g]	50				

\* The data in the area 20 % - 100 % of rated load F

\*\* Realized on board in connection cable, 1.7 m from sensor housing or 0.3 m from cable end (temperature range limited to 0 ... 60 °C)

\*\*\* The sensor is not designed for a very large number of load change cycles up to the nominal load

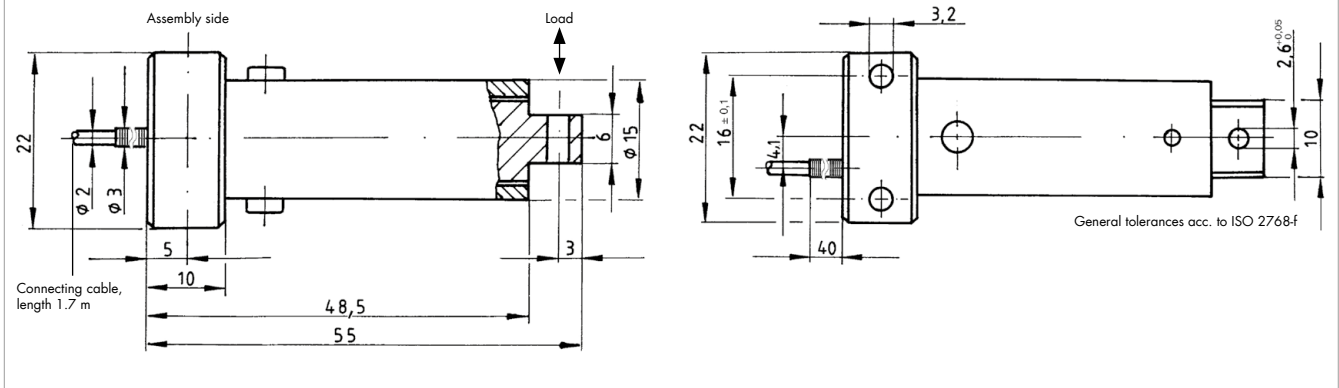
Dimensional drawing – Measuring ranges from  $\leq 0 \dots \pm 20 \text{ N}$  | from  $\leq 0 \dots \pm 4.4 \text{ lbs}$ 

## Electrical termination

### Output signal

burster load cells are based on a strain-gage Wheatstone bridge. This measurement principle means that the output voltage mV/V is highly dependent on the sensor supply voltage. Our website contains details of suitable instrumentation amplifiers, indicator and display devices and process instruments.

### burster TEDS



The "burster Transducer Electronic Data Sheet" (TEDS) is a memory in which identification data of the sensor, calibration data and other sensor parameters are saved. In conjunction with your own suitable burster device, there is the option of performing a simple adjustment in order to achieve the maximum accuracy of the measuring chain. A simple sensor exchange is thus possible in just a few steps without losing precision.

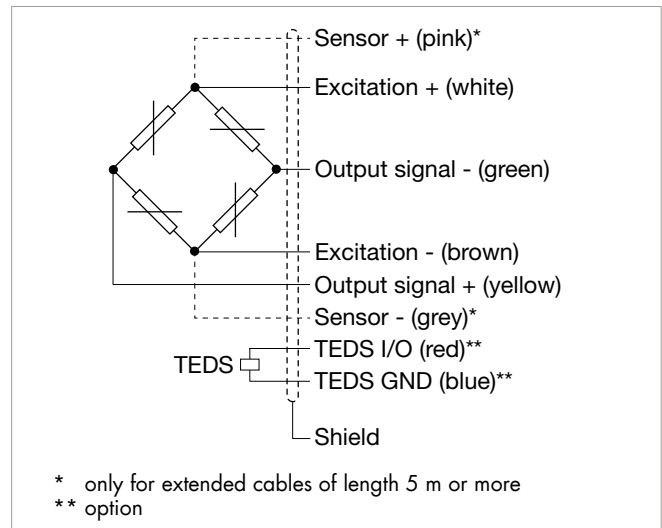

8510	-	5001	5002	5005	5010	5020
Measuring range from 0 ...		$\pm 1 \text{ N}$	$\pm 2 \text{ N}$	$\pm 5 \text{ N}$	$\pm 10 \text{ N}$	$\pm 20 \text{ N}$
<b>Electrical termination</b>						
Specifications		highly flexible, oil resistant, drag chains suitable				
Cable fastening		cable cover				
Bending protection		bend protection spring				
Bending radius		three times the diameter for fixed cable, ten times the diameter for cable permanently moving				
Cable model		PUR, $\phi = 2.0 \text{ mm}$				

## Accessories

### Connectors and units

#### Order Code

Connectors	
9941	Connectors 12 pin, suitable to all burster desktop units
9900-V209	Connectors 9 pin, suitable to SENSORMASTER, DIGIFORCE® and TRANS CAL
9900-V229	Connectors 9 pin with TEDS
9900-V245	Connectors 8 pin, suitable to ForceMaster
Units	
7281-V0001	Mobile measuring device with strain gage simulator and sensor test ( $R_{it}$ , $R_{gr}$ , Shunt, $R_{ISO}$ )
refer to section 9	Sensor electronics, amplifier and process control units like digital indicator model 9180, model 9163, modular amplifier model 9250 or DIGIFORCE® model 9307

## Calibration

#### Test and calibration certificate

Supplied with the sensor	Amongst other data, includes figures for zero point, full-scale output and calibration offset
--------------------------	---

#### Standard factory calibration certificate for load cells or measurement chains (WKS)

Optionally available	Our standard factory calibration certificate includes 11 measurement points, starting at zero, spread evenly in 20% steps over the full measuring range, for increasing and decreasing load under the same installation conditions. Factory calibrations can be performed in the compression and/or tension direction depending on the sensor type.
----------------------	---

#### Special factory calibration certificate for load cells or measurement chains (WKS)

On request	We are happy to calibrate sensors and measurement chains to the customer's specification.
------------	---

#### German-accredited DAkkS calibration certificate for sensors and measurement chains (DKD)

Optionally available	Our DAkkS-certified calibration laboratory provides calibration certificates to DIN EN ISO 376. The calibration certificate includes 21 measurement points, starting at zero, spread evenly in 10% steps over the measuring range, for increasing and decreasing load under various installation conditions. DAkkS calibrations can be performed in the compression and/or tension direction depending on the sensor type.
----------------------	--

## Order Code

Measuring range	Code	Measuring range
0 ... ±1 N	5 0 0 1	0 ... ±0.224 lbs
0 ... ±2 N	5 0 0 2	0 ... ±0.449 lbs
0 ... ±5 N	5 0 0 5	0 ... ±1.124 lbs
0 ... ±10 N	5 0 1 0	0 ... ±2.248 lbs
0 ... ±20 N	5 0 2 0	0 ... ±4.4 lbs

										Delivery ex stock at short notice								
										N	0	0	0	S	0	0	0	
<b>8</b>	<b>5</b>	<b>1</b>	<b>0</b>	<b>-</b>						<b>-</b>				<b>0</b>	<b>S</b>	<b>0</b>	<b>0</b>	<b>0</b>

■ Nominal sensitivity/not standardized	N
■ Standardization at 1.0 mV/V ***	C
*** temperature range limited to 0 ... +60 °C	
■ Connection cable 1.7 m (Standardization 2 m)	0
■ Connection cable 3 m	F
■ Connection cable 5 m	G
■ Connection cable 3 m extended *	L
■ Connection cable 5 m extended * (with sens line)	M
* shortened delivery time compared with cable length 3 m and 5 m in one piece	
■ Open cable ends + 6 cm single wires	0
■ 9 pins Sub-D connector model 9900-V209	B
■ 9 pins Sub-D connector model 9900-V209 for 9163-V3xxxx	E
■ 12 pins round connector model 9941 for burster desktop devices	F
■ 9 pins Sub-D connector with burster TEDS model 9900-V229 ***	T
■ 8 pins coupling connector model 9900-V245 for 9110	H
*** temperature range limited to 0 ... +60 °C	
■ Non-linearity 0.2 % F.S. **	S
■ Non-linearity 0.075 % F.S. **	L

\*\* The data in the area 20 % - 100 % of rated load  $F_{nom}$

## Note

### ■ Brochure

Our brochure „Load cells for production, automation, R&D and quality assurance“ is available for download on our website. It contains numerous applications, detailed product specifications and overviews.

### ■ Product videos

Watch our **How-to-do video** at: [www.youtube.com/bursterVideo](http://www.youtube.com/bursterVideo)



### ■ CAD data

Download via [www.burster.com](http://www.burster.com) or directly at [www.traceparts.com](http://www.traceparts.com)

