



PLFN

负载极大的精密减速机
且性能极高
安装便捷

PLFN 配有标准化的法兰接口，因此安装简便。这款直齿高精度行星减速机适用于需实现最高效能和扭矩的应用情况。其倾斜力矩很高，即使轴向和径向力极高，也能有出色表现。

The precision planetary gearbox for maximum loads and the highest performance – fast and easy to install

Our **PLFN** features a standardized flange interface for ease of installation. The straight-teeth precision planetary gearbox has been designed for the highest performance and torque. Its high tilting moment delivers the best performance even under the highest radial and axial forces.

额定扭矩 Nominal output torque	27 - 1800 Nm
径向力 Radial force	2150 - 33000 N
轴向力 Axial force	4300 - 15000 N
回程间隙 Torsional backlash	1 - 5 arcmin
防护等级 Protection class	IP65

结构尺寸
Frame sizes

- 64
- 90
- 110
- 140
- 200

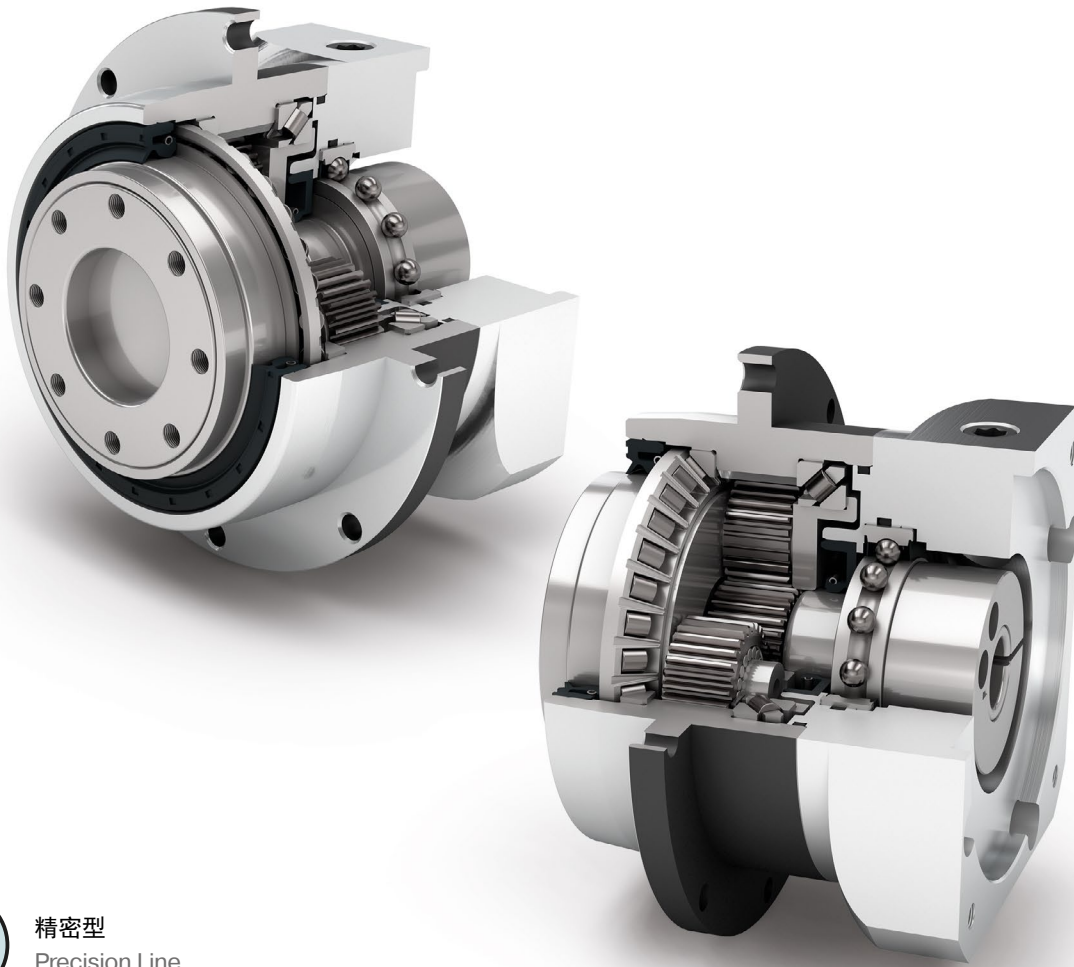

精密型
Precision Line

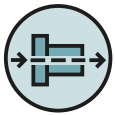

同轴减速机
Coaxial gearbox



直齿
Spur gear



配有预紧的角接触滚子轴承
Preloaded angular contact roller bearings



法兰输出轴 (按 ISO 9409 标准)
Flange output shaft (ISO 9409)



可选: 降低回程间隙
Option: Reduced backlash



旋转方向 同方向
Equidirectional rotation

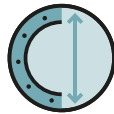

圆形特大号输出法兰
Extra large round type output flange



径向轴密封
Rotary shaft seal



行星齿轮架 (笼状结构)
Planet carrier in cage design



可选: 装有小齿轮的高精度减速机
140页
Option: Planetary gearbox with
mounted pinion on page 140

技术特点的详细解释, 请从第169页读起。
Detailed explanations of the technical features starting on page 169.

Code	减速机参数	Gearbox characteristics			PLFN064	PLFN090	PLFN110	PLFN140	PLFN200	p ⁽¹⁾
	使用寿命 (L _{10h})	Service life (L _{10h})	t _L	h	20.000					
	T _{2N} × 0,88 时的使用寿命	Service life at T _{2N} × 0,88			30.000					
	满载时效率 ⁽²⁾	Efficiency at full load ⁽²⁾	η	%	97					1
					96					2
	最低工作温度	Min. operating temperature	T _{min}	°C	-25					
	最高工作温度	Max. operating temperature	T _{max}		90					
	防护等级	Protection class			IP65					
S	标准润滑	Standard lubrication			润滑油 (终生润滑) / Oil (lifetime lubrication)					
F	食品级润滑	Food grade lubrication			润滑油 (终生润滑) / Oil (lifetime lubrication)					
L	低温润滑 ⁽³⁾	Low temperature lubrication ⁽³⁾			润滑油 (终生润滑) / Oil (lifetime lubrication)					
	安装位置	Installation position			任意 / Any					
S	标准回程间隙	Standard backlash	j _t	arcmin	< 3					1
R	降低回程间隙	Reduced backlash			< 5					2
	抗扭刚度 ⁽²⁾	Torsional stiffness ⁽²⁾	C _g	Nm / arcmin	7,7	22,0	59,0	156,0	330,0	1
					14,8	40,5	92,0	255,0	636,0	
					7,6	18,5	58,0	177,0	391,0	2
					14,7	38,0	91,0	264,0	656,0	
	减速机重量 ⁽²⁾	Gearbox weight ⁽²⁾	m _G	kg	1,3 - 1,4	2,9 - 3,0	5,0 - 5,3	12,9 - 13,5	37,0 - 39,2	1
					1,9	3,4 - 3,5	6,0 - 6,3	15,0 - 15,6	43,5 - 45,9	
S	标准的箱体表面	Standard surface			箱体: 钢 - 热处理后氧化 (黑色) Housing: Steel - heat-treated and post-oxidized (black)					
	运行噪音 ⁽⁴⁾	Running noise ⁽⁴⁾	Q _g	dB(A)	60	62	65	70	74	
	基于减速机输入法兰的最大弯矩 ⁽⁵⁾	Max. bending moment based on the gearbox input flange ⁽⁵⁾	M _b	Nm	18	38	80	180	300	1
					18	18	38	80	180	2

输出轴载荷	Output shaft loads			PLFN064	PLFN090	PLFN110	PLFN140	PLFN200	p ⁽¹⁾	
20,000 h 的径向力 ⁽⁶⁾⁽⁷⁾	Radial force for 20,000 h ⁽⁶⁾⁽⁷⁾	F _{r20.000h}	N	2150	3950	4900	12000	33000		
20,000 h 的轴向力 ⁽⁶⁾⁽⁷⁾	Axial force for 20,000 h ⁽⁶⁾⁽⁷⁾	F _{a20.000h}		4300	8200	9500	8500	15000		
30,000 h 的径向力 ⁽⁶⁾⁽⁷⁾	Radial force for 30,000 h ⁽⁶⁾⁽⁷⁾	F _{r30.000h}		1900	3500	4350	11000	29500		
30,000 h 的轴向力 ⁽⁶⁾⁽⁷⁾	Axial force for 30,000 h ⁽⁶⁾⁽⁷⁾	F _{a30.000h}		3800	7200	8400	7500	13500		
最大径向力 ⁽⁷⁾⁽⁸⁾	Maximum radial force ⁽⁷⁾⁽⁸⁾	F _{r Stat}		2150	3950	4900	12000	33000		
最大轴向力 ⁽⁷⁾⁽⁸⁾	Maximum axial force ⁽⁷⁾⁽⁸⁾	F _{a Stat}		4300	8200	9500	8500	15000		
20,000 h 倾斜力矩 ⁽⁶⁾⁽⁸⁾	Tilting moment for 20,000 h ⁽⁶⁾⁽⁸⁾	M _{K20.000h}		Nm	132	326	475	1219		4957
30,000 h 倾斜力矩 ⁽⁶⁾⁽⁸⁾	Tilting moment for 30,000 h ⁽⁶⁾⁽⁸⁾	M _{K30.000h}			117	289	422	1117		4431

转动惯量	Moment of inertia			PLFN064	PLFN090	PLFN110	PLFN140	PLFN200	p ⁽¹⁾
转动惯量 ⁽²⁾	Mass moment of inertia ⁽²⁾	J	kgcm ²	0,217	0,580	2,036	7,313	26,880	1
				0,288	0,920	2,942	12,365	61,170	
				0,209	0,211	0,546	1,951	6,911	2
				0,243	0,269	0,737	2,784	11,813	

(1) 减速机级数
 (2) 传动比相关的数值可在 Tec Data Finder 中检索 - www.neugart.com
 (3) T_{min} = -40°C. 理想运行温度最高为 50°C
 (4) 距离减速机 1 m; 在输入转速为 n₁=3000 min⁻¹ 且无负荷时测得; i=5
 (5) 最大电机重量* (单位: kg) = 0.2 × M_b / 电机长度 (单位: m)
 * 电机重量对称分布
 * 水平和固定的安装位置
 (6) 数据以 n₂=100 min⁻¹ 的输出轴转速为准。
 (7) 以输出轴中心为准
 (8) 更改 T_{2N}, F_r, F_a 以及周期和轴承使用寿命时, 数值存在偏差 (部分较高)。利用 NCP 针对应用进行专门设计 - www.neugart.com

(1) Number of stages
 (2) The ratio-dependent values can be retrieved in Tec Data Finder - www.neugart.com
 (3) T_{min} = -40°C. Optimal operating temperature max. 50°C
 (4) Sound pressure level from 1 m, measured on input running at n₁=3000 rpm no load; i=5
 (5) Max. motor weight* in kg = 0.2 × M_b / motor length in m
 * with symmetrically distributed motor weight
 * with horizontal and stationary mounting
 (6) These values are based on an output shaft speed of n₂=100 rpm
 (7) Based on the end of the output shaft
 (8) Other (sometimes higher) values following changes to T_{2N}, F_r, F_a, cycle, and service life of bearing. Application specific configuration with NCP - www.neugart.com

输出扭矩	Output torques			PLFN064	PLFN090	PLFN110	PLFN140	PLFN200	i ⁽¹⁾	p ⁽²⁾
额定输出扭矩 ⁽³⁾	Nominal output torque ⁽³⁾	T _{2N}	Nm	60	140	300	600	1300	4	1
				65	140	260	750	1600	5	
				45	90	180	530	1300	7	
				40	80	150	450	1000	8	
				27	60	125	305	630	10	
				77	150	300	1000	1800	16	2
				77	150	300	1000	1800	20	
				65	140	260	900	1800	25	
				77	150	300	600	1800	32	
				65	140	260	750	1800	40	
				65	130	260	620	1525	50	
				40	80	150	450	1000	64	
				27	60	125	305	630	100	
				96	224	480	960	2080	4	
104	224	416	1200	2560	5					
72	144	288	848	2080	7					
64	128	240	720	1600	8					
43	96	200	488	1008	10					
最大输出扭矩 ⁽⁴⁾	Max. output torque ⁽⁴⁾	T _{2max}	Nm	123	240	480	1600	2880	16	2
				123	240	480	1600	2880	20	
				104	224	416	1440	2880	25	
				123	240	480	960	2880	32	
				104	224	416	1200	2880	40	
				104	208	416	992	2440	50	
				64	128	240	720	1600	64	
				43	96	200	488	1008	100	

⁽¹⁾ 传动比 (i=n₁/n₂)

⁽²⁾ 减速机级数

⁽³⁾ 利用 NCP 针对应用进行专门设计 – www.neugart.com

⁽⁴⁾ 允许输出轴转动30.000转; 参见第 158 页

⁽¹⁾ Ratios (i=n₁/n₂)

⁽²⁾ Number of stages

⁽³⁾ Application specific configuration with NCP – www.neugart.com

⁽⁴⁾ 30,000 rotations of the output shaft permitted; see page 159

输出扭矩	Output torques			PLFN064	PLFN090	PLFN110	PLFN140	PLFN200	i ⁽¹⁾	p ⁽²⁾
急停扭矩 ⁽³⁾	Emergency stop torque ⁽³⁾	T _{2Stop}	Nm	120	280	650	1300	2700	4	1
				130	280	650	1500	3200	5	
				90	175	340	1300	2600	7	
				90	200	380	1000	2600	8	
				90	200	480	750	1350	10	
				150	300	650	2000	3600	16	2
				150	300	650	2000	3600	20	
				150	300	650	1800	3600	25	
				150	300	650	1500	3600	32	
				150	300	650	1500	3600	40	
				150	300	650	1500	3600	50	
				80	200	380	1000	2600	64	
				80	200	480	750	1350	100	

输入转速	Input speeds			PLFN064	PLFN090	PLFN110	PLFN140	PLFN200	i ⁽¹⁾	p ⁽²⁾
T _{2N} 和 S1 时的平均热输入转速 ⁽⁴⁾⁽⁵⁾	Average thermal input speed at T _{2N} and S1 ⁽⁴⁾⁽⁵⁾	n _{1N}	min ⁻¹	2100 ⁽⁶⁾	1750 ⁽⁶⁾	1300 ⁽⁶⁾	850 ⁽⁶⁾	500 ⁽⁶⁾	4	1
				2450 ⁽⁶⁾	2100 ⁽⁶⁾	1650 ⁽⁶⁾	950 ⁽⁶⁾	600 ⁽⁶⁾	5	
				3200 ⁽⁶⁾	3000 ⁽⁶⁾	2350 ⁽⁶⁾	1400 ⁽⁶⁾	850 ⁽⁶⁾	7	
				3550 ⁽⁶⁾	3350 ⁽⁶⁾	2650 ⁽⁶⁾	1650 ⁽⁶⁾	1000 ⁽⁶⁾	8	
				4100 ⁽⁶⁾	4000 ⁽⁶⁾	3150 ⁽⁶⁾	2050 ⁽⁶⁾	1300 ⁽⁶⁾	10	
				3700 ⁽⁶⁾	3850 ⁽⁶⁾	3150 ⁽⁶⁾	1700 ⁽⁶⁾	1100 ⁽⁶⁾	16	2
				4200 ⁽⁶⁾	4450 ⁽⁶⁾	3750 ⁽⁶⁾	2100 ⁽⁶⁾	1350 ⁽⁶⁾	20	
				4500 ⁽⁶⁾	4500 ⁽⁶⁾	4000 ⁽⁶⁾	2500 ⁽⁶⁾	1550 ⁽⁶⁾	25	
				4500 ⁽⁶⁾	4500	4000	3500 ⁽⁶⁾	2000 ⁽⁶⁾	32	
				4500	4500	4000	3500 ⁽⁶⁾	2250 ⁽⁶⁾	40	
				4500	4500	4000	3500	2750 ⁽⁶⁾	50	
				4500	4500	4000	3500	3000 ⁽⁶⁾	64	
				4500	4500	4000	3500	3000	100	
				最高机械输入转速 ⁽⁴⁾	Max. mechanical input speed ⁽⁴⁾	n _{1Limit}	min ⁻¹	14000	10000	
14000	14000	10000	8500					6500		2

(1) 传动比 (i=n₁/n₂)
 (2) 减速级数
 (3) 允许 1000 次
 (4) 利用 NCP 针对应用设计转速 – www.neugart.com
 (5) 定义请参见第 158 页
 (6) 在 50% T_{2N} 输出和 S1 模式下的平均热传动转速

(1) Ratios (i=n₁/n₂)
 (2) Number of stages
 (3) Permitted 1000 times
 (4) Application-specific speed configurations with NCP – www.neugart.com
 (5) See page 159 for the definition
 (6) Average thermal input speed at 50% T_{2N} and S1

PLFN064
PLFN090

PLFN110

PLFN140
PLFN200

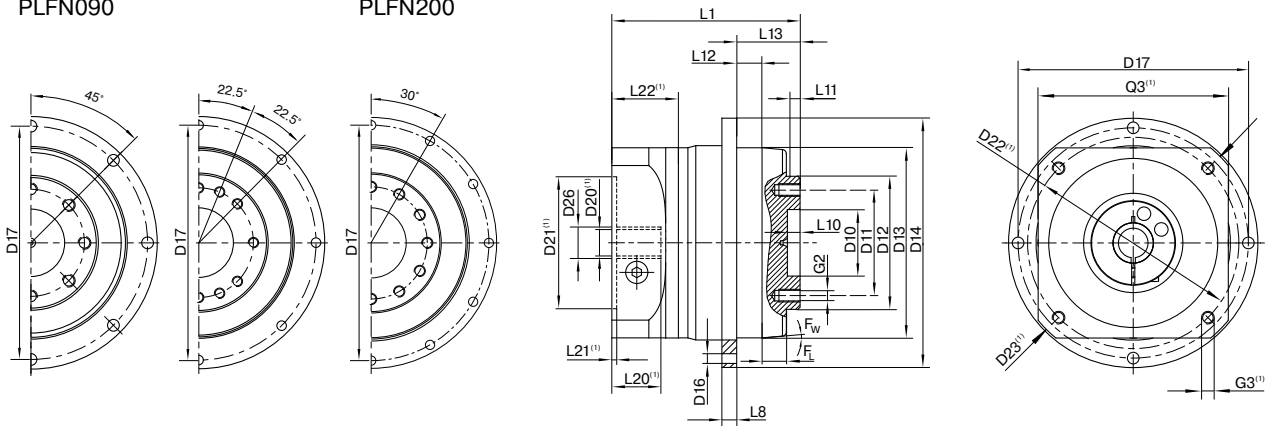

图示为带平键的 PLFN090 / 1 级 / 法兰输出轴 / 19 mm 锁紧系统 / 适配电机法兰 - 2 件式 - 圆形通用法兰 / B5 电机法兰类型
Drawing corresponds to a PLFN090 / 1-stage / flange output shaft / 19 mm clamping system / motor adaptation - 2-part - round universal flange / B5 flange type motor

(1) 具体尺寸视电机/减速机法兰而定。可以在 www.neugart.com 下 Tec Data Finder。中针对每个电机适配电机特有的输入法兰几何尺寸。
(1) The dimensions vary with the motor/gearbox flange. The input flange dimensions can be retrieved for each specific motor in Tec Data Finder at www.neugart.com

几何尺寸 ⁽²⁾	Geometry ⁽²⁾			PLFN064	PLFN090	PLFN110	PLFN140	PLFN200	p ⁽³⁾	Code
输出端定位凹槽直径	Centering diameter output shaft	D10	H7	20	31,5	40	50	80		
输出端安装孔节圆直径	Pitch circle diameter output shaft	D11		31,5	50	63	80	125		
法兰输出轴的直径	Flange output shaft diameter	D12	h7	40	63	80	100	160		
输出法兰定位凸台直径	Centering diameter output flange	D13		64	90	110	140	200		
输出法兰直径	Flange diameter output	D14		86	118	145	179	247		
输出端安装孔直径	Mounting bore output	D16		4,5 8x45°	5,5 8x45°	5,5 8x45°	6,6 12x30°	9 12x30°		
输出法兰安装孔节圆直径	Pitch circle diameter output flange	D17		79	109	135	168	233		
最小总长	Min. total length	L1		71	89	108	157	212,5	1	
				99,5	111	130	187,5	264	2	
输出端法兰厚度	Flange thickness output	L8		4	7	8	10	12		
输出轴定位凸台深度	Centering depth output shaft	L10		4,5	6,5	6,5	6,5	10		
		L11		3	6	6	6	8		
输出法兰定位凸台深度	Centering depth output flange	L12		10	12	12	14	17,5		
输出法兰长度	Output flange length	L13		19,5	30,0	29,0	38,0	50,0		
电机轴直径j6/k6	Motor shaft diameter j6/k6	D20		更多信息见第 155/156 页 More information on page 155/156						
输入端锁紧系统直径	Clamping system diameter input	D26								
法兰输出轴 (相似的 EN ISO 9409-1)	Flange output shaft (similar EN ISO 9409-1)									
数量 x 螺纹 x 深度	Number x thread x depth	G2		8 x M5x7	8 x M6x10	12 x M6x12	12 x M8x15	12 x M10x20		D
带有配合销孔的法兰输出轴 (EN ISO 9409-1)	Flange output shaft with dowel hole (EN ISO 9409-1)									
配合销孔 x 深度	Dowel hole x depth	D15	H7	5x5	6x6	6x6	8x8	10x10		E
数量 x 螺纹 x 深度	Number x thread x depth	G2		7 x M5x7	7 x M6x10	11 x M6x12	11 x M8x15	11 x M10x20		

(2) 所有的尺寸单位为mm
(3) 减速机级数

(2) Dimensions in mm
(3) Number of stages